

The Psychology of Contrarian Investing

December 2013

Behavioral finance, broadly defined, has given us a fairly comprehensive understanding of investors' real decision processes. It has taught us to set aside the timeworn fiction of "economic man"—the well-informed, utility-maximizing homunculus with stable preferences and superb computational skills—in favor of more realistic models of choice under risk.¹ Investors, we now see, are prone to cognitive errors, reluctant to realize losses, and overconfident in their own ability but fearful that other market participants know something they don't. Moreover, investors seek not only utilitarian rewards but expressive and emotional benefits as well, such as status and a sense of belonging to a community.² Thanks to Herbert Simon, Daniel Kahneman, Richard Thaler, Meir Statman, and many others, we have a general psychology that illuminates the cognitive and affective recesses of investment decision-making.

A contrarian stance is not a symptom of a personality disorder.

Contrarian investors can be situated within the framework of the general psychology; there is no need for an abnormal psychology to make sense of their behavior. A contrarian stance is not a symptom of a personality disorder. If some contrarians are antisocial or apathetic, that is because, just like other investors, they are people. Nonetheless, contrarians may reasonably be expected to share some abiding personality traits, such as a spirit of self-reliance, a penchant for critical thinking, and a strong future time orientation.

My limited objective in this short piece is to suggest some possible directions for experimental research on the psychology of contrarian investors. C. Thomas Howard provides a useful frame of reference in his important 2014 paper on behavioral portfolio management (BPM). His trenchant description of emotional crowds focuses on certain characteristics that may help differentiate the hypothetical attributes of a lifelike contrarian.

Emotional Crowds



AUTHORS

Philip Lawton

In Howard's account, the first principle of BPM is that security prices are predominately set by emotional crowds comprising investors whose purchase and sale decisions are based on heuristic shortcuts, anecdotal evidence, and visceral reactions to unfolding events.³ In terms Kahneman made familiar, emotional investors operate primarily at the level of System 1: their thinking is fast and automatic.⁴ Emotional crowds, Howard says, are propelled by two forces: a deep-seated aversion to short-term losses and a compulsive need for social validation.⁵

BPM assumes, as others have established, that markets are not very efficient. Nor are emotional crowds wise in the sense that the averages of individual market participants' valuations would tend to approximate securities' true, fundamental, or inherent values.⁶ James Surowiecki identified four conditions that characterize wise crowds: diversity of opinion, independence, decentralization, and aggregation.⁷ Emotional crowds in the financial markets satisfy the last two conditions; participants can draw on their own resources, and there is a mechanism—the pricing mechanism itself—for reducing many individual judgments to a collective decision. But emotional crowds are unlikely to exhibit a strong diversity of opinion, and their members are certainly not independent in Surowiecki's sense. It cannot be said that "people's opinions are not determined by the opinions of those around them;" on the contrary, in emotional crowds, people take their cues from one another. They think what they think others think.

For the present purpose, it is enough to treat the emotional crowd as an assembly of undifferentiated investors. Indeed, from one perspective, it seems entirely fitting; the self can be submerged and carried along in a mass movement. Nonetheless, a more granular description of the crowd's composition (along the lines, for instance, of Andrew Lo's species of investors)⁸ might facilitate empirical research and lead to further insights. Traditional index investing is a trend-following strategy—constituent weights rise and fall with prices—and it contributes to stock market volatility,⁹ but passive investors do not necessarily belong to the emotional crowd. The decision to invest passively does not, in itself, indicate anything about an individual's cognitive style.

Howard's view of the price-setting mechanism does not rule out the possibility of rational investing. It does, however, call for a new kind of rationality in investment decision-making. In this view, rational investors are continually aware of other market participants' tendencies to overpay and overreact. (Rational investors also recognize that their own emotions are at work, but they try to bring them to the surface and subject them to cognitive control.)¹⁰ Because market prices are not primarily based upon economic forecasting or security analysis, rational investors today are at least as much concerned with others' behavioral signals as they are with asset class correlations or discounted cash flows. Howard calls them behavioral-data investors (BDIs) and characterizes their cognitive style as System 2 thinking—"effortful, high-concentration, and complex."¹¹

Howard's second basic principle (of three) is that BDIs earn superior returns. There is, however, a certain emotional cost. He writes:

It would seem easy to build superior performing portfolios, but doing so would mean taking positions that are opposite the crowd. The powerful need for social validation acts as a strong deterrent for many investors, discouraging them from pursuing such an approach. It is tough to leave the emotional crowd and become a BDI.¹²

Howard does not simply identify rational investing with contrarian investing ("taking positions that are opposite the crowd"); the BPM approach is considerably broader and more nuanced.¹³ Nonetheless, in his framework, contrarians can qualify as rational investors. Let us consider how they might differ in thought, attitude, and behavior from the members of emotional crowds.

A Contrarian Perspective on Prices

A superficial statement of the contrarian position would simply hold that the emotional crowd is foolish and will sooner or later be proven dead wrong. No doubt there are contrarians who earn superior long-term returns without much mental effort. Nonetheless, if the contrarian approach is rational, then its view on the pricing mechanism can be articulated and justified.

One important version of contrarian investment theory sees security prices as "noisy." In information theory, noise in a transmission channel distorts the information-bearing signal. (**Figure 1.**) Think of static interfering with a radio broadcast.

Figure 1. Schematic Diagram of a General Communication System

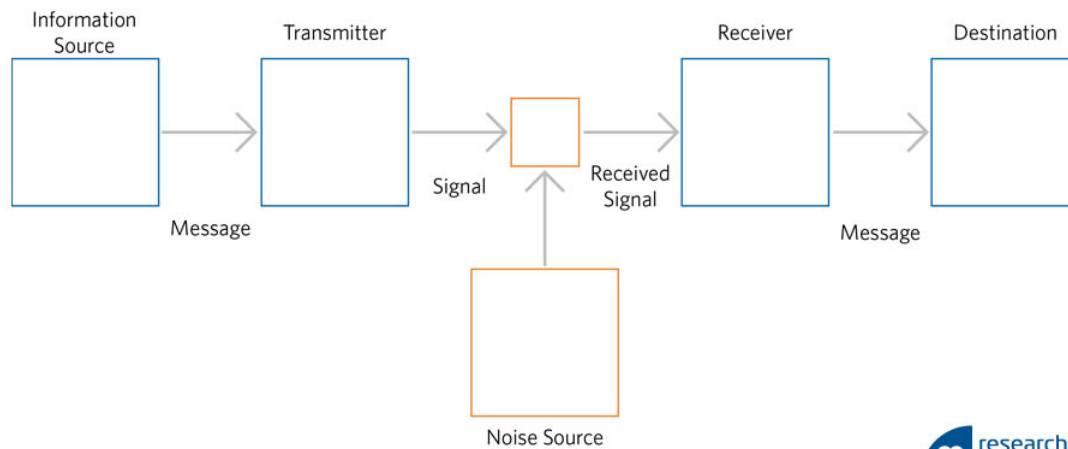

Source: Shannon and Weaver (1963), 34.

Any use of the above content is subject to all important legal disclosures, disclaimers and terms of use found at www.researchaffiliates.com, which are fully incorporated by reference as if set out herein at length.

By analogy, in modern portfolio theory, financial markets—the transmission channels—are at least fairly efficient (or clear), and security prices primarily reflect information (or news). In the contrarian view, however, markets are more than a little inefficient because many participants initiate transactions inspired by static. “Perhaps they think the noise they are trading on is information,” wrote Fischer Black. “Or perhaps they just like to trade.”¹⁴

In addition, the contrarian approach (unlike BPM)¹⁵ recognizes that, although stocks exhibit short-term momentum, over the long run both the level of the equity market and the prices of individual securities are mean-reverting.¹⁶ Empirical studies demonstrate that stocks whose prices have been trending have a pronounced tendency to turn around and head in the direction of their long term average prices. For example, Fama and French (1988) found “consistent evidence that stock returns are positively serially correlated over short horizons, and negatively autocorrelated over long horizons.”¹⁷ Mean reversion can continue for up to 10 years, but the strongest effect shows up over the period from two to five years after a reversal.¹⁸

Contrarian investors profit from long-term mean reversion in noisy security prices by contra-trading against price when they rebalance their portfolios. In this context, rebalancing means selling winners (stocks which have appreciated) and buying losers (stocks which have lately declined in price). Winners are more likely to be overvalued; losers, undervalued. Contrarian investors are unaffected by subsequent mean reversion in the overvalued, high-price stocks they have divested, and they stand to gain if and when the undervalued, low-price stocks reverse direction and start to rise. Ironically, contrarian investing—taking positions opposite the emotional crowd—simply comes down to buying low and selling high. Contrarians are eminently rational.¹⁹

With this background, let’s explore how contrarian investors might differ from the emotional crowd along the two key psychological dimensions Howard identified. Are contrarians also loss-averse? Do they stand equally in need of social validation?

Short-Term Loss Aversion

People typically love to win and hate even more to lose. Winning is rewarding; it makes people feel good about themselves. Correlatively, losing is not only a disappointing outcome with a certain cost; it can be sharply experienced as a self-inflicted insult to the ego, particularly if the one who loses has narrowly framed the competition as a singularly important event. Kahneman said, “When

you sell a loser, you don't just take a financial loss; you take a psychological loss from admitting you made a mistake. You are punishing yourself when you sell."²⁰

Loss aversion refers to the experimentally established fact that decision makers have a natural tendency to weigh losses more heavily than gains. Richard Thaler states, "losses hurt roughly twice as much as gains feel good," and he observes that "even investors with long-term horizons appear to care about short-term gains and losses."²¹

Contrarian investors may sustain deep market value losses, but they are generally in position to sidestep the underlying psychological issue with which other investors have to contend: overcoming their reluctance to *realize* a loss. Rebalancing a contrarian portfolio entails selling the stocks which have appreciated and reinvesting the proceeds in low price stocks, including those whose market values have recently declined. Consequently, contrarian investors are more likely to realize gains than losses.

Nonetheless, contrarians do not avoid absolute market value losses in bear markets, and they may have to tolerate months or even years of relative underperformance when prices are trending upward. If they are somewhat less vulnerable to short-term loss aversion, it is probably because they have chosen a long-term investment strategy; and it is possible that this choice reflects a persistent attitude toward the future. Joseph Nuttin, a psychologist who studied personality and motivation, wrote, "Generally speaking, one could say that the future is the 'mental space' in which human needs are processed into long-term goals and behavioral projects."²²

Some subjects see the future as determined by chance; others regard it as largely dependent upon their own actions.

Although the future is a mental representation, it appears to have greater reality for achievement-oriented people. Indeed, there is a telling connection between individuals' outlook on the future and their self-understanding as active persons in a dynamic relationship with the world and other people. Psychological studies reveal that, while some subjects see the future as determined by chance, others regard it as largely dependent upon their own actions.²³ I would hazard that active long-term investors chiefly belong to the latter group.

In principle, surveys and experiments could establish whether contrarian investors have a greater-than-average future time orientation. However, the measurement issues are thorny, especially when future time orientation is considered as an abiding personality trait rather than a situation-specific or experimentally induced response.²⁴ Future time orientation may also be strongly influenced by cultural and historical factors; one would not expect similar averages from studies conducted in Belgium in the 1980s and the United States in the 2010s.

Social Validation

Investments are risky; that's in the nature of the game. But investment decision-making itself is fraught with uncertainty. Investors may doubt their assumptions ("Am I using the right discount rate?") or experience misgivings about their knowledge ("Why is the other side willing to enter this transaction?"). And, as Robert Cialdini explains, it is precisely in such conditions of uncertainty that people turn to the "principle of social proof," which holds that one of the ways we go about determining what is correct, or what to do, is to seek out what other people think is right. "In general," he wrote, "when we are unsure of ourselves, when the situation is unclear or ambiguous, when uncertainty reigns, we are most likely to look to and accept the actions of others as correct."²⁵

Adam Smith remarked that the more we mistrust our own feelings and opinions, the more weight we give others'. In his words:

The agreement or disagreement both of the sentiments and judgments of other people with our own, is, in all cases, it must be observed, of more or less importance to us, exactly in proportion as we ourselves are more or less uncertain about the propriety of our own sentiments, about the accuracy of our own judgments.²⁶

The question for a psychology of contrarian investing is whether contrarians are less influenced than average market participants by other investors' "sentiments and judgments." I have mentioned that active long-term investors, in general, seem likely to believe that their behavior in the present can affect the future. This perspective implies a proactive attitude and a certain self-reliance.²⁷ It seems reasonable to anticipate that contrarians will be predisposed to gather information, analyze it, and reach an independent conclusion. It also seems sensible not to expect the same of the emotional crowd, whose members may tend to see mental effort as an avoidable transaction cost. Recall that System 1 is their characteristic mode of thinking.

The more we mistrust our own feelings and opinions, the more weight we give others'.

Within the financial services industry, all investment professionals are ethically obligated to use reasonable care and exercise independent judgment; and there is no *a priori* reason to suppose that contrarians are distinctively less (or, for that matter, more) reliant upon social validation than other practitioners.

Conclusion

Taking investment decisions seriously means not only acting competently but also understanding and accepting the affective consequences of making choices whose outcomes cannot be known in advance. This is tough on all investors, but arguably hardest on contrarians. Although they may expect to earn superior returns over full market cycles, they fall behind (and managers risk losing clients) when stocks are rising and everybody else is making money. Contrarian investors might sometimes feel isolated and embattled. It is natural to wonder whether they have characteristic personality traits and modes of thought that uniquely equip them to handle the stress of standing against the emotional crowd.

At least one way of articulating contrarian thought sees security prices as noisy and mean-reverting. Adopting this viewpoint may reflect the contrarian's personal preference, but it is not a purely arbitrary choice; noise-in-price models have proven theoretically sound and empirically sensible. The potential long-term outperformance of contrarian investing depends upon profiting from mean reversion at the level of the market and/or individual stocks. As Kalesnik (2013) points out, the emotional cost of the contrarian strategy may be reduced by investing in a transparent fundamentals-weighted index fund or ETF that rebalances through rules-based trading against price movements.²⁸

Finally, I have suggested that contrarian investors may exhibit a number of normal traits to a higher-than-average degree. They include a proclivity for self-reliance and critical thinking, an active orientation toward the future, and a relatively low need for social validation. Hypothesis testing might determine whether contrarians actually have these characteristics.

The author would like to acknowledge thoughtful comments and suggestions from Denis Chaves, Vitali Kalesnik, Engin Kose, Michele

Endnotes

1. Simon (1955) wrote, "Broadly stated, the task is to replace the global rationality of economic man with a kind of rational behavior that is compatible with the access to information and the computational capacities that are *actually* possessed by organisms, including man, in the kinds of environments in which such organisms exist." (Page 99; emphasis added.) Joan Robinson (1962) debunked the "metaphysical concept" of utility, and Kahneman and Tversky (1979) roundly demonstrated the inadequacy of utility theory.
2. Statman (2011), Introduction.
3. Howard (2013), 5-7.
4. Kahneman (2011), 20-22. Kahneman attributes the terms "System 1" and "System 2" to psychologists Keith Stanovich and Richard West.
5. Howard (2013), 3.
6. In principle, a security's true value is the present value of projected cash flows discounted at a rate that properly reflects the uncertainty of receiving them in full and on time. Nonetheless, the true value is unobservable, and estimating it is quite unlike guessing the number of marbles in a jar.
7. Surowiecki (2004), 7-8.
8. "By *species*, I mean distinct groups of market participants, each behaving in a common manner. For example, pension funds may be considered one species; retail investors another; market makers a third; and hedge-fund managers a fourth." Lo (2004), 23.
9. Sullivan and Xiong (2012).
10. Lane (1991), 108.
11. Howard (2013), 3.
12. Howard (2013), 9.
13. For example, Howard recommends that investors implementing BPM be aware of market sentiment; create buckets for short-term income and liquidity, long-term capital growth, and alternative investments; and select managers on the basis of their strategy, consistency, and willingness to take high-conviction positions. Howard (2013), 18-22, 25.
14. Black (1986), 531.
15. Howard asserts in passing that patterns of short-term momentum and mean reversion "tend to be transitory in nature." Howard (2013), 25.
16. Research Affiliates investment professionals Ryan Larson (2013) and Vitali Kalesnik (2013), respectively, provide clear and well-supported explanations of momentum and mean reversion.
17. Fama and French (1988), Abstract and pages 3-4.

18. See Kalesnik (2013).
19. They may also be smarter than the average bear. The fascinating study of IQ and trading behavior in Finland conducted by Grinblatt et al. (2012) did not specifically consider intelligence in relation to investment strategy. Nonetheless, the study found that high-IQ investors were more likely than low-IQ investors to hold (sell) stocks that hit a monthly low (high). “High IQ investors thus appear to be more contrarian than low-IQ investors with respect to these reference prices.” This is especially true when extreme price movements occur. Nor is this pattern necessarily motivated by the disposition effect. Citing other studies, Grinblatt and his co-authors state, “by selling stocks at monthly highs and holding stocks at monthly lows, high-IQ investors are more likely to be following a rational liquidity provision strategy than a psychological bias that diminishes returns.” (Page 347.)
20. Quoted in Zweig (2007).
21. Thaler (1999), 15. Benartzi and Thaler (1995) made note of investors’ propensity to check investment performance frequently and attributed the equity premium in part to what they called “myopic loss aversion.” Kahneman (2011) wrote, “The combination of loss aversion and narrow framing is a costly curse. Individual investors can avoid that curse, achieving the emotional benefits of broad framing while also saving time and agony, by reducing the frequency with which they check how well their investments are doing.” (Page 339.)
22. Nuttin (1985), 40.
23. Nuttin (1985), 29.
24. Gjesme (1983) explains the measurement issues.
25. Cialdini (2009), Chapter 4.
26. Smith (1759), III.2.16.
27. Here, too, the social environment matters; even within a single culture and economy, prevalent attitudes change over time. Citing a major study, Lane reports that many more Americans saw the self as efficacious, and independence as a source of well-being, in 1976 than in 1957. Lane (1991), 173.
28. Kalesnik (2013) stated, “It is exceedingly difficult for investors and managers alike to hold fast when the market continues to move against them. One potential solution is to strip contrarian investing of its emotional component by committing long-term assets to a transparent algorithmic rebalancing strategy. Smart Beta strategies—a recent innovation in financial management—are transparent, non-price weighted solutions. Transparency and dispassionate rebalancing rules help significantly mitigate the agency problems facing regular managers.”

References

- Benartzi, Shlomo and Richard H. Thaler. 1995. “Myopic Loss Aversion and the Equity Premium Puzzle.” *Quarterly Journal of Economics*, vol. 110, no. 1 (February):73-92.
- Black, Fischer. 1986. “Noise.” *Journal of Finance*, vol. 41, no. 3 (July):529-543.
- Cialdini, Robert B. 2009. *Influence: The Psychology of Persuasion*. Revised edition. New York: HarperCollins e-books.
- Fama, Eugene F., and Kenneth R. French. 1988. “Dividend Yields and Expected Stock Returns.” *Journal of Financial Economics*, vol. 22, no. 1 (October):3-25.

- Gjesme, Torgrim. 1983. "On the Concept of Future Time Orientation: Considerations of Some Functions' and Measurements' Implications." *International Journal of Psychology*, vol. 18, no. 1 (February/December):443-461.
- Grinblatt, Mark, Matti Keloharju, and Juhanni T. Linnainmaa. 2012. "IQ, Trading Behavior, and Performance." *Journal of Financial Economics*, vol. 104, no. 2 (May):339-362.
- Howard, C. Thomas. 2014. "Behavioral Portfolio Management." (December 31).
- Kahneman, Daniel, and Amos Tversky. 1979. "Prospect Theory: An Analysis of Decision Under Risk." *Econometrica*, vol. 47, no. 2 (March):263-292.
- Kahneman, Daniel. 2011. *Thinking, Fast and Slow*. New York: Farrar, Straus and Giroux.
- Kalesnik, Vitali. 2013. "Smart Beta and the Pendulum of Mispricing." *Simply Stated*, Research Affiliates (3rd Quarter).
- Lane, Robert E. 1991. *The Market Experience*. Cambridge: Cambridge University Press.
- Larson, Ryan. 2013. "Hot Potato: Momentum As An Investment Strategy." *Fundamentals*, Research Affiliates (August).
- Lo, Andrew W. 2004. "The Adaptive Markets Hypothesis: Market Efficiency from an Evolutionary Perspective." *Journal of Portfolio Management*, vol. 30, no. 5 (30th Anniversary):15-29.
- Nuttin, Joseph, with the collaboration of Willy Lens. 1985. *Future Time Perspective and Motivation: Theory and Research Method*. Leuven, Belgium: Leuven University Press and Hillsdale, NJ: Lawrence Erlbaum Associates, Inc., Publishers.
- Robinson, Joan. 1962. *Economic Philosophy*. New Brunswick, NJ: Transaction Publishers.
- Shannon, Claude E. and Warren Weaver. 1963. *The Mathematical Theory of Communication*. Urbana and Chicago: University of Illinois Press.
- Simon, Herbert A. 1955. "A Behavioral Model of Rational Choice." *Quarterly Journal of Economics*, vol. 69, no. 1 (February):99-118.
- Smith, Adam. 1759; 1982. *The Theory of Moral Sentiments*. Edited by D.D. Raphael and A.L. Macfie. Indianapolis, IN: Liberty Fund.
- Statman, Meir. 2011. *What Investors Really Want: Discover What Drives Investor Behavior and Make Smarter Financial Decisions*. New York: McGraw-Hill.
- Sullivan, Rodney N. and James X. Xiong. 2012. "How Index Trading Increases Market Vulnerability." *Financial Analysts Journal*, vol. 68, no. 2 (March/April):70-84.
- Surowiecki, James. 2004. *The Wisdom of Crowds: Why the Many Are Smarter Than the Few and How Collective Wisdom Shapes Business, Economies, Societies, and Nations*. New York: Doubleday.
- Thaler, Richard H. 1999. "The End of Behavioral Finance." *Financial Analysts Journal*, vol. 55, no. 6 (November/December):12-17.
- Zweig, Jason. 2007. *Your Money and Your Brain: How the New Science of Neuroeconomics Can Help Make You Rich*. New York: Simon & Schuster.

The material contained in this document is for informational purposes only. It is not intended as an offer or a solicitation for the purchase and/or sale of any security, derivative, commodity, or financial instrument, nor is it advice or a recommendation to enter into any transaction. Research results relate only to a hypothetical model of past performance (i.e., a simulation) and not to actual results or historical data of any asset management product. Hypothetical investor accounts depicted are not representative of actual client accounts. No allowance has been made for trading costs or management fees, which would reduce investment performance. Actual investment results will differ. Simulated data may have under- or over-compensated for the impact, if any, of certain market factors. Simulated returns may not reflect the impact that material economic and market factors might have had on the advisor's decision-making if the advisor were actually managing clients' money. Simulated data is subject to the fact that it is designed with the benefit of hindsight. Simulated returns carry the risk that actual performance is not as depicted due to inaccurate predictive modeling. Simulated returns cannot predict how an investment strategy will perform in the future. Simulated returns should not be considered indicative of the skill of the advisor. Investors may experience loss of all or some of their investment. Index returns represent backtested performance based on rules used in the creation of the index, are not a guarantee of future performance, and are not indicative of any specific investment. Indexes are not managed investment products and cannot be invested in directly. This material is based on information that is considered to be reliable, but Research Affiliates, LLC ("RA") and its related entities (collectively "Research Affiliates") make this information available on an "as is" basis without a duty to update, make warranties, express or implied, regarding the accuracy of the information contained herein. Research Affiliates is not responsible for any errors or omissions or for results obtained from the use of this information.

Nothing contained in this material is intended to constitute legal, tax, securities, financial or investment advice, nor an opinion regarding the appropriateness of any investment. The information contained in this material should not be acted upon without obtaining advice from a licensed professional. RA is an investment adviser registered under the Investment Advisors Act of 1940 with the U.S. Securities and Exchange Commission (SEC). Our registration as an investment adviser does not imply a certain level of skill or training. RA is not a broker-dealer and does not effect transactions in securities.

Investors should be aware of the risks associated with data sources and quantitative processes used to create the content contained herein or the investment management process. Errors may exist in data acquired from third party vendors, the construction or coding of indices or model portfolios, and the construction of the spreadsheets, results or information provided. Research Affiliates takes reasonable steps to eliminate or mitigate errors and to identify data and process errors, so as to minimize the potential impact of such errors; however, Research Affiliates cannot guarantee that such errors will not occur. Use of this material is conditioned upon, and evidence of, the user's full release of Research Affiliates from any liability or responsibility for any damages that may result from any errors herein.

The trademarks Fundamental Index™, RAFI™, Research Affiliates Equity™, RAE™, and the Research Affiliates™ trademark and corporate name and all related logos are the exclusive intellectual property of RA and in some cases are registered trademarks in the U.S. and other countries. Various features of the Fundamental Index methodology, including an accounting data-based non-capitalization data processing system and method for creating and weighting an index of securities, are protected by various patents of RA. (See applicable US Patents, Patent Publications and protected trademarks located at <https://www.researchaffiliates.com/legal/disclosures#patent-trademarks-and-copyrights>, which are fully incorporated herein.) Any use of these trademarks, logos, or patented methodologies without the prior written permission of RA is expressly prohibited. RA reserves the right to take any and all necessary action to preserve all of its rights, title, and interest in and to these marks and patents.

The views and opinions expressed are those of the author and not necessarily those of RA. The opinions are subject to change without notice.

©2022 Research Affiliates, LLC. All rights reserved. Duplication or dissemination prohibited without prior written permission.

AMERICAS

Research Affiliates, LLC

620 Newport Center Drive, Suite 900
Newport Beach, California 92660
USA

+1.949.325.8700
info@researchaffiliates.com

EUROPE

Research Affiliates Global Advisors (Europe) Ltd

16 Berkeley Street
London W1J 8DZ
United Kingdom

+44 (0) 203 929 9880
uk@researchaffiliates.com